

0154618en	005
0209	

Pump

PST2 400 PSTF2 400



OPERATOR'S MANUAL

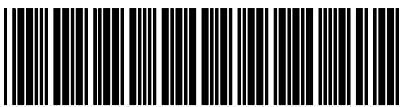

0 1 5 4 6 1 8 E N

Foreword

Machines covered in this manual

Machine	Item Number
PST2 400	0009112
PSTF2 400	0620435

This manual provides information and procedures to safely operate and maintain this Wacker Neuson model. For your own safety and protection from injury, carefully read, understand and observe the safety instructions described in this manual.

Keep this manual or a copy of it with the machine. If you lose this manual or need an additional copy, please contact Wacker Neuson Corporation. This machine is built with user safety in mind; however, it can present hazards if improperly operated and serviced. Follow operating instructions carefully! If you have questions about operating or servicing this equipment, please contact Wacker Neuson Corporation.

The information contained in this manual was based on machines in production at the time of publication. Wacker Neuson Corporation reserves the right to change any portion of this information without notice.

All rights, especially copying and distribution rights, are reserved.

Copyright 2009 by Wacker Neuson Corporation.

No part of this publication may be reproduced in any form or by any means, electronic or mechanical, including photocopying, without express written permission from Wacker Neuson Corporation.

Any type of reproduction or distribution not authorized by Wacker Neuson Corporation represents an infringement of valid copyrights and will be prosecuted. We expressly reserve the right to make technical modifications, even without due notice, which aim at improving our machines or their safety standards.

Foreword	3
1. Safety Information	7
1.1 Operating and Electrical Safety	8
1.2 Informational Labels	8
2. Operation	9
2.1 Names of Parts	9
2.2 Prior to Operation	10
2.3 Installation	10
2.4 Installing the Float (if equipped)	13
2.5 Electrical Wiring	15
2.6 Electrical Circuit Diagrams	17
2.7 Operation	19
2.8 Automatic Operation (PSTF2 400 only)	22
2.9 Residue Plate	23
3. Maintenance	24
3.1 Periodic Maintenance Table	24
3.2 Maintenance and Inspection	25
3.3 Disassembly and Reassembly	27
3.4 Disassembly	28
3.5 Impeller Inspection	29
3.6 Impeller Reassembly	30
3.7 Troubleshooting	31
4. Technical Data	32
4.1 Standard Specifications	32
4.2 Operating Specifications	33
4.3 Dimensions	34

1. Safety Information

This manual contains DANGER, WARNING, CAUTION, *NOTICE* and NOTE callouts which must be followed to reduce the possibility of personal injury, damage to the equipment, or improper service.



This is the safety alert symbol. It is used to alert you to potential personal injury hazards. Obey all safety messages that follow this symbol to avoid possible injury or death.



DANGER

DANGER indicates a hazardous situation which, if not avoided, will result in death or serious injury.



WARNING

WARNING indicates a hazardous situation which, if not avoided, could result in death or serious injury.



CAUTION

CAUTION indicates a hazardous situation which, if not avoided, could result in minor or moderate injury.

NOTICE: Used without the safety alert symbol, **NOTICE** indicates a situation which, if not avoided, could result in property damage.

Note: *Contains additional information important to a procedure.*

1.1 Operating and Electrical Safety



To reduce risk of electric shock, connect only to a properly grounded, grounding-type receptacle.

Risk of electric shock—this pump has not been investigated for use in swimming pool areas.

An acceptable motor-control switch shall be provided at the time of installation according to local codes and regulations.

To reduce risk of electric shock, follow instructions in this manual for proper installation.

CAUTION: This pump may automatically restart. Prior to working on the pump or control panel, all supply circuits must be disconnected.

CAUTION: Risk of shock—do not remove cord and strain relief.

1.2 Informational Labels

Label	Meaning
	<p>A nameplate listing the model number, item number, revision number, and serial number is attached to each unit. Please record the information found on this plate so it will be available should the nameplate become lost or damaged. When ordering parts or requesting service information, you will always be asked to specify the model number, item number, revision number, and serial number of the unit.</p>

2. Operation

2.1 Names of Parts

See Graphic: wc_gr001699

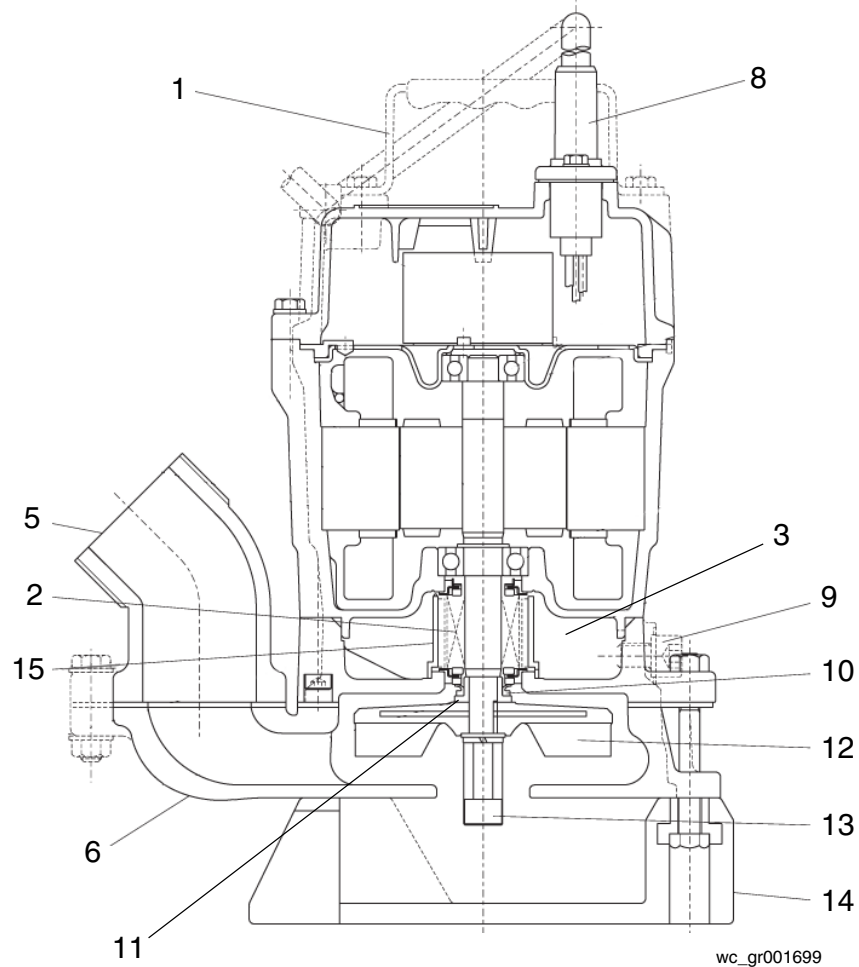

Ref	Description	Ref	Description
1	Lifting handle	9	Oil plug
2	Mechanical seal	10	Dust seal
3	Lubricant	11	Sleeve
4	Oil housing	12	Impeller
5	Coupling	13	Stirrer nut
6	Volute	14	Strainer
7	Gasket	15	Oil lifter
8	Cable assembly		

2.2 Prior to Operation

When the pump is delivered, first perform the following checks:

- Inspection

While unpacking, inspect the product for damage during shipment, and make sure all bolts and nuts are tightened properly.

- Specification check

Check the model number to make sure it is the product that was ordered. Be certain it is the correct voltage and frequency.

Note: *If there is any problem with the product as shipped, contact your nearest dealer or Wacker Neuson representative at once.*

- Product specifications



Do not operate this product under any conditions other than those for which it is specified. Failure to observe this precaution can lead to electrical shock, current leakage, fire, water leakage or other problems.

2.3 Installation



If the pump is used to drain a swimming pool, the pump must be connected to a Ground Fault Interrupter (GFI).

If the pump is used in fountains, the pump must be connected to a Ground Fault Interrupter (GFI).

The pump must not be used when people are in the water.

Leakage of pump lubricants may cause pollution of water.

Proper plug must be provided according to local codes and standards. Refer to wiring diagram.

Do not use this pump in liquids other than water, such as oil, salt water, or organic solvents.

Use with a power supply voltage within $\pm 5\%$ of the rated voltage.

Do not use in water temperatures outside the range of 0–40°C (32–104°F) which can lead to failure, current leakage or shock.

Do not use in the vicinity of explosive or flammable materials.

Use only in fully assembled state.

Note: *Consult your local dealer or Wacker Neuson representative before using with any liquids other than those indicated in this document.*

Preparing for installation

Before installing the pump at a work site, you will need to have the following tools and instruments ready:

- Insulation resistance tester (megohmmeter)
- AC voltmeter
- AC ammeter (clamp-on type)
- Bolt and nut tighteners
- Power supply connection tools (screwdriver or box wrench)

Note: *Please also read the instructions that come with each of the test instruments.*

Checks to Make Before Installation

When a three-prong grounded plug is used:

Use the megohmmeter to measure the motor insulation resistance between the grounding prong and each one of the two power prongs.

When connection wires are used:

With the megohmmeter, measure the insulation resistance between the ground wire (Green) and each one of the two power wires.

Reference insulation resistance: 20MW or greater.

Note: *The reference insulation resistance (20MW or greater) is the value when the pump is new or has been repaired. For the reference value after installation, see the Periodic Maintenance table.*

Precautions in Installation



When installing the pump, pay close attention to its center of gravity and weight. If it is not lowered into place correctly, it may fall and be damaged or cause injury.

When transporting the machine by hand, be sure to employ manpower commensurate with the weight of the machine. To avoid back injury when lifting the machine, bend the knees to pick it up rather than bending your back only.



Do not under any circumstances install or move the pump by suspending it from the cable assembly. The cable may be damaged, causing current leakage, shock, or fire.

2.3.1

Avoid dropping the pump or other strong impact. Lift the pump by holding it firmly with the hands or by attaching a rope or chain to the lifting handle.

Note: *On cable assembly handling, see Electrical Wiring.*



Avoid dry operation, which will not only lower performance but can cause the pump to malfunction, leading to electrical leakage and shock.

- 2.3.2 Install the pump in a location with sufficient water level, where water collects readily.

Note: See Operation (“Operating Water Level”) for the water level necessary for operation.

Note: The discharge end of the hose should be located higher than the water surface. If the end of the hose is submerged, water may flow back to the pump when the pump is stopped; and if the hose end is lower than the water surface, water may overflow when the pump is turned off.



CAUTION

If large quantities of earth are sucked up, damage resulting from friction in the pump can lead to current leakage and shock.

- 2.3.3 Use the pump in the upright position. To prevent the strainer from becoming submerged in mud, causing it to suck in sand or debris, mount it on a block or other firm base.
- 2.3.4 If used in a permanent installation where the pump is not readily accessible after installation, please contact Wacker Neuson for a duplicate nameplate to be installed at the wellhead or on the control box so that it will be readily visible.

2.4 Installing the Float (if equipped)

See graphic: wc_gr005664

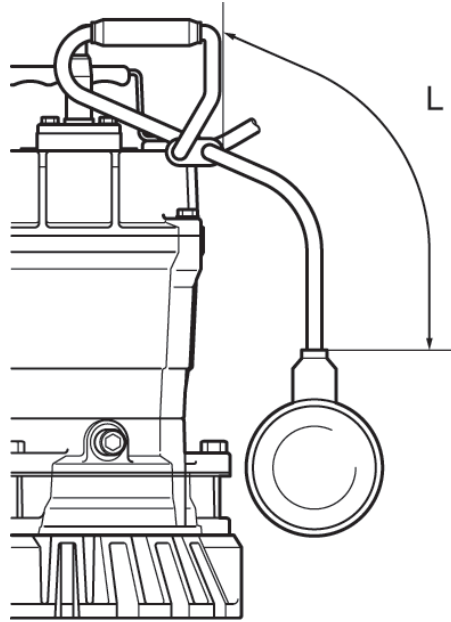

wc_gr005664

2.4.1 Set the length of the float lead wire to the dimension indicated below. Failure to set the correct lead wire length will lead to improper operation of the pump.

Pump model	Length "L"
PSTF2 400	150 mm (5.9 in.)

NOTICE: Install the float so that it moves freely up and down. If the float binds or catches, it will cause the pump to operate improperly.

Notes:

2.5 Electrical Wiring

Performing electrical wiring



Electrical wiring should be performed by a qualified person in accord with all applicable regulations. Failure to observe this precaution not only risks breaking the law but is extremely dangerous.

Incorrect wiring can lead to current leakage, electrical shock or fire.

Always make sure the pump is equipped with the specified overload protectors and fuses or breakers, so as to prevent electrical shock from a current leak or pump malfunction.

Operate within the capacity of the power supply and wiring.

Grounding



Do not use the pump without first grounding it properly. Failure to ground it can lead to electrical shock from a current leak or pump malfunction.



Do not attach the grounding wire to a gas pipe, water pipe, lightning arrester or telephone grounding wire. Improper grounding can result in electrical shock.

Connecting the power supply



Before connecting wires to the terminal, make certain the power supply is turned off (circuit breaker, etc.), to avoid electrical shock, shorting, or unexpected starting of the pump, leading to injury.

Before inserting the power supply plug, make certain the power supply is turned off (circuit breaker, etc.), to avoid electrical shock, shorting, or unexpected starting of the pump, leading to injury.



Do not use the pump with the cable assembly or plug connected loosely, which can result in electric shock, shorting, or fire.

Draw power from a dedicated power outlet rated at 15 A or above. Sharing the outlet with other equipment may cause overheating at the branch outlet and could result in fire.

- The three-prong grounded plug shall be connected as shown in the drawing.

NOTICE: Be sure to use a dedicated power supply with a ground leakage circuit breaker.

Note: *The shape of the plug may differ from that shown in the illustration.*

See Graphic: wc_gr000242

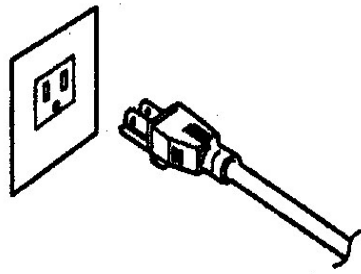

wc_gr000242



CAUTION

Cable Assembly

If it is necessary to extend the cable assembly, use a core size equal to or larger than the original. This is necessary not only to avoid a performance drop, but to prevent cable overheating which can result in fire, electrical leakage or electrical shock.

If a cable with cut insulation or other damage is submerged in the water, there is a danger of damage to the pump, electrical leakage, electrical shock, or fire.

Be careful not to let the cable assembly be cut or become twisted. This may result in damage to the pump, electrical leakage, electrical shock, or fire.

If it is necessary to submerge the connection wires of the cable assembly in water, first seal the wires completely in a molded protective sleeve, to prevent electrical leakage, electrical shock, or fire.

Do not allow the cable assembly wires or power supply plug to become wet.

Make sure the cable does not become excessively bent or twisted, and does not rub against a structure in a way that might damage it.

If used in a deep-well installation, the cable assembly should be secured every twenty feet.

2.6 Electrical Circuit Diagrams

See Graphic: wc_gr006190

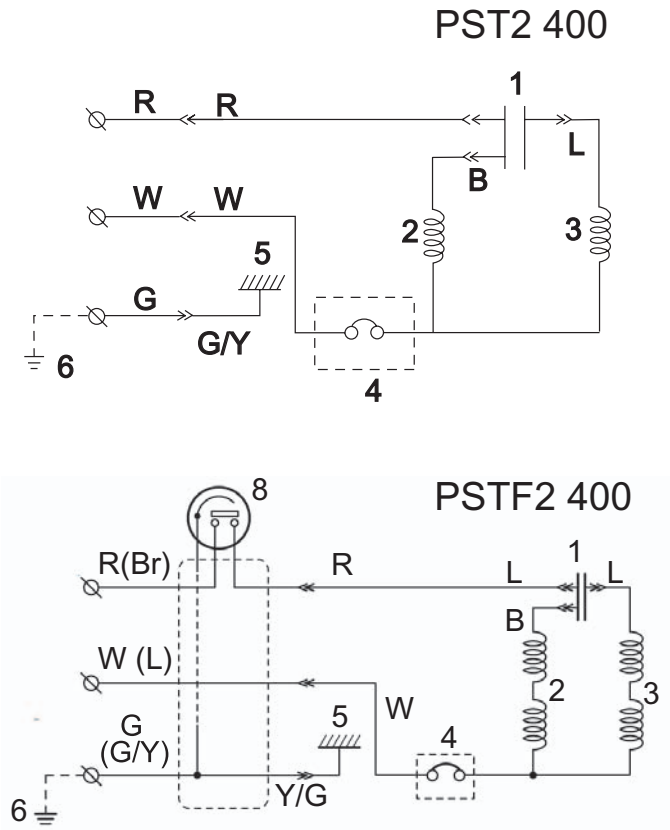

wc_gr006190



If connected to a circuit protected by a fuse, use a time-delay fuse with this pump.

Ref.	Description	Ref.	Description
1	Capacitor	5	Frame grounding
2	Main coil	6	Ground
3	Auxiliary coil	8	Float switch (normally open contact)
4	Miniature protector		

Wire Colors					
B	Black	V	Violet	Or	Orange
G	Green	W	White	Pr	Purple
L	Blue	Y	Yellow	Sh	Shield
P	Pink	Br	Brown	LL	Light Blue
R	Red	Cl	Clear	G/Y	Green/Yellow
T	Tan	Gr	Gray		

2.7 Operation

Before starting

- 2.7.1 Make sure once again that the product is of the correct voltage and frequency rating.

NOTICE: Using the product at other than rated voltage and frequency will not only lower its performance but may damage the product.

Note: *Confirm the rated voltage and frequency on the model nameplate.*

- 2.7.2 Confirm the wiring, supply voltage, circuit breaker capacity, and motor insulation resistance.

Reference insulation resistance = 20 MW or greater.

Note: *The reference insulation resistance (20 MW or greater) is the value when the pump is new or has been repaired. For the reference value after installation see “Periodic Maintenance Table.”*

- 2.7.3 The setting on the circuit breaker or other overload protector should be made in accord with the rated current of the pump.

Note: *See “Operating Specifications” for the rated current of the pump.*

- 2.7.4 When powering the pump with a generator, be certain the generator is sized to supply the required power for the pump and any other equipment powered by the generator.

Test Operation



WARNING

Do not operate the pump while it is suspended in the air. The recoil may result in injury or other major accident.



WARNING

Do not start the pump when people are standing next to it. A current leak can result in electrical shock.

Run the pump for a short time (3–10 minutes) and confirm the following:

- Using an ammeter (clamp-on type), measure the operating current at the L1 and L2 phase wires on the terminal.

COUNTERMEASURE: If the operating current exceeds the rated value, pump motor overload may be a cause. Make sure the pump has been installed under proper conditions as described in *Installation*.

- Using an AC voltmeter (tester), measure voltage at the terminals. Supply voltage tolerance: within $\pm 5\%$ of rated voltage.

COUNTERMEASURE: If the supply voltage is outside the tolerance, possible causes are the power supply capacity or an inadequate extension cable. Look again at the wiring diagram and make sure the conditions are proper.



In case of very excessive vibration, unusual noise or odor, turn off the power immediately and consult your nearest dealer or Wacker representative. Continuing to operate the pump under abnormal conditions may result in electrical shock, fire, or current leakage.

Operation



The pump may become very hot during operation. Be careful not to contact the pump accidentally to avoid being burned.

Make sure no extraneous objects such as pins, nails or other metal objects are sucked into the pump. These can damage the pump or cause it to malfunction, and can result in electrical shock or electrical leakage.

When the pump is not used for an extended period, be sure to turn off the power (circuit breaker, etc.). Deterioration of the insulation may lead to electrical leakage, electrical shock, or fire.

In case of a power outage, turn off the power to the pump to avoid having it start unexpectedly when the power is restored, presenting serious danger to people in the vicinity.



The pump may become hot during operation. Do not touch an operating pump. Allow the pump to cool before handling.

Pay careful attention to the water level while the pump is operating. Dry operation may cause the pump to malfunction.

Note: See section “Operating water level” for the water level necessary for operation.

Sharp bends in the hose, especially near its base, may cause air pockets to form resulting in idle operation. Lessen the degree of bending while continuing to operate the pump.



Operating water level

Do not operate the pump below the C.W.L. (Continuous running Water Level) indicated below. Failure to observe this condition may result in damage to the pump, current leakage or electrical shock.

See Graphic: wc_gr001222

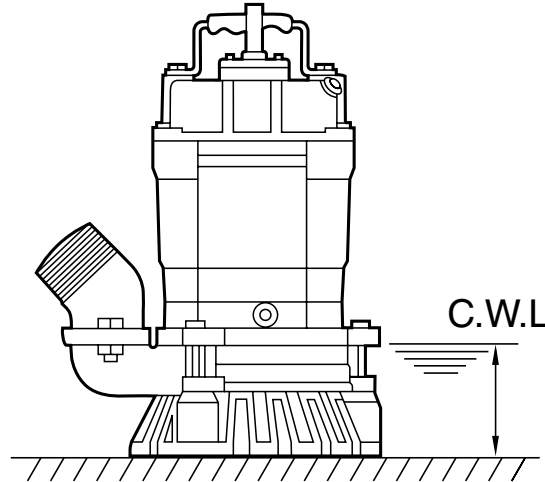

wc_gr001222

NPT 45-degree hose coupling is standard for the US market.

Pump Model	Continuous running Water Level
PST2 400 w/strainer	90mm (3.5")
PST2 400 w/residue plate	10mm (0.4")
PSTF2 400	120mm (4.75")

Motor Protection System (Motor Protector)

The pump has a built-in motor protection system (Miniature Protector). If the motor overheats, for reasons such as the following, the pump will automatically stop operating regardless of the water level, to protect the motor:

- Change in supply voltage polarity
- Overload
- Open-phase operation or operation under constraint

Note: Always determine the cause of the problem and resolve it before resuming operation. Simply repeating cycles of stopping and restarting will result in damage to the pump. Do not continue operation at very low lift, low water level, or while the strainer is clogged with debris. Not only will performance suffer, but also such conditions may cause noise, heavy vibration, and malfunctioning.

2.8 Automatic Operation (PSTF2 400 only)

See Graphic: *wc_gr005666*

The PSTF2 400 pump is equipped with a float switch to detect the water level. The float switch (**a**) enables the pump to perform an automatic drainage operation when connected to a continuous power supply.

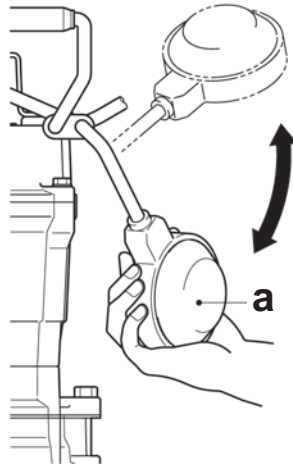

wc_gr005666

Connect the power and perform a trial operation as follows:

- 2.8.1 Move the float switch down to its lowest position.
- 2.8.2 Raise the float switch. This will start the pump.
- 2.8.3 Lower the float switch to its original position. This will stop the pump.
- 2.8.4 Repeat this cycle two or three more times to verify the operation.

Note: *The trial operation must be completed within one minute.*



If the pump operates abnormally (i.e. exhibits an unusually large amount of vibration, noise, or odor), disconnect the power supply immediately and contact your Wacker Neuson dealer. Do not operate the pump in this condition, otherwise there is a risk of current leakage, electrical shock, or fire.

2.9 Residue Plate

See graphic: *wc_gr001144*

The residue plate kit contains the residue plate, washers, and bolts. Reuse nuts from pump assembly.

- 2.9.1 Remove the strainer **(3)** by loosening the three nuts **(1)** and removing the three bolts **(2)**. Keep nuts for reuse.
- 2.9.2 Position washers **(4)** and attach the residue plate **(5)** with new bolts **(6)** included with kit.

Note: *Be certain to use washers to prevent motor shaft stirrer nut from protruding through residue plate.*

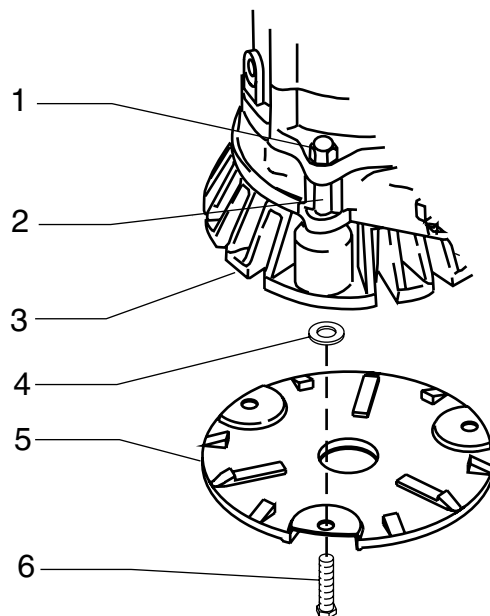

wc_gr001144

3. Maintenance

3.1 Periodic Maintenance Table

Pump	Weekly	Monthly	Every 1000 hrs.	Every 2000 hrs.
Measure insulation resistance. Reference insulation resistance = 1MW or greater. (1)	■			
Measure operating current. Compare with rated current.	■			
Measure supply voltage. Compare with allowable range (within $\pm 5\%$ of rated voltage).	■			
Pump inspection. A noticeable drop in performance may indicate wear in the impeller, etc., or else clogging of the strainer, etc. Remove the clogged debris and replace any worn parts.		■		
Lubricant inspection.			■	
Change lubricant.				■
Designated lubricant: SAE 10W/20W. (2)				■
Change mechanical seal. (3)				■
Overhaul. This should be carried out even if there are no problems with the pump. The frequency depends on how continuously the pump is in use. (4)				■

(1) If the insulation resistance has become noticeably lower than the previous inspection, an inspection of the motor will be necessary.

(2) See Lubricant Inspection and Lubricant Change in this section.

(3) Specialized know-how is required for inspecting and replacing the mechanical seal. Consult with your nearest dealer or Wacker Neuson representative.

(4) Consult with your nearest dealer or Wacker Neuson representative regarding overhauls.

3.2 Maintenance and Inspection

Regular maintenance and inspections are a necessity for continued efficient functioning of the pump. If any abnormal conditions are noticed, refer to the *Troubleshooting* section and take corrective measures immediately. It is recommended that a spare pump be kept ready in case of any problems.

Prior to inspecting



Before inspecting the pump, make certain the power supply (circuit breaker, etc.) is turned off. Then, unplug the cable assembly from the receptacle or detach it from the terminals. Failure to follow this precaution may result in a serious accident from electrical shock or unexpected starting of the pump motor.

3.2.1 Washing the pump

Remove accumulated matter from the surface of the pump and wash it with clean water. Take special care to remove any debris from the impeller.

3.2.2 Inspecting the pump exterior

Look for any peeling or chipped paint, and make sure the nuts and bolts are fastened tightly. Any cracks in the surface should be repaired by cleaning that area, drying it and then applying a touch-up coating.

Note: *Touch-up paint is not supplied. Note that some kinds of damage or looseness may require that the unit be disassembled for repairs. Please consult your nearest dealer or Wacker Neuson representative.*

Storage

When the pump is out of use for an extended period, wash it and dry it thoroughly, then store it indoors.

Note: *Always run a test operation before putting the pump back into service.*

If the pump is left in the water, it should be run a minimum of once a week.

- Inspecting Lubricant

Remove the oil plug and tilt the pump to drain a small amount of lubricant. If the lubricant is milky white or has water mixed in with it, the mechanical seal may be faulty. In this case the pump will need to be disassembled and repaired.

- Replacing Lubricant

Remove the oil plug and drain all the lubricant, then replace it with the specified amount.

Note: *Worn lubricant and other waste products should be disposed of by a qualified agent, in accord with applicable laws. The oil plug gasket should be replaced each time the lubricant is inspected or changed.*

See Graphic: wc_gr000245

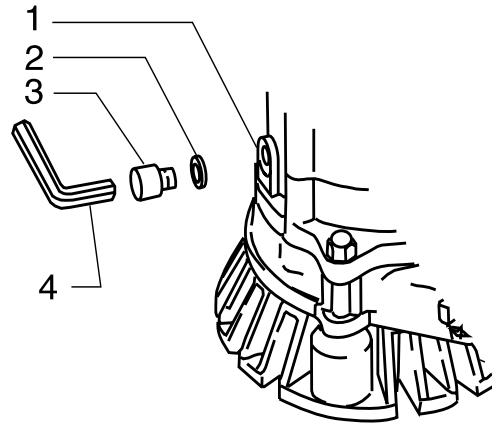

wc_gr000245

Ref.	Description	Ref.	Description
1	Oil inlet	3	Oil plug
2	Gasket	4	Allen wrench

Pump Model	Lubricant Capacity
PST2 400 PSTF2 400	160 ml (5.4 fl. oz.)

Replacement Parts

The table lists the parts that need to be replaced periodically. Replace these using the recommended frequency as a guideline.

Part	Replacement Frequency
Mechanical seal	When lubricant in oil compartment becomes milky.
Lubricant (SAE 10W/20W)	Every 2,000 hours or 12 months, whichever comes first.
Gasket	Each time pump is disassembled or inspected.
Dust seal	When ring is worn, and each time pump is disassembled or inspected.
Sleeve	When it becomes worn.

3.3 Disassembly and Reassembly



Before disassembling the pump, make certain the power supply (circuit breaker, etc.) is turned off. Then, unplug the cable assembly from the receptacle or detach it from the terminals. To avoid electrical shock, DO NOT work with wet hands.

NEVER check the operation of any parts (impeller rotation, etc.) by turning on the power while the unit is partially assembled. Failure to observe these precautions may result in a serious accident.

DO NOT disassemble or repair any parts other than those designated here. If repairs are necessary in any other than the designated parts, consult your nearest dealer or Wacker Neuson representative. Improper repairs can result in electrical leakage, electrical shock, fire, or water leaks.

After reassembly, ALWAYS perform a test operation before resuming use of the pump. Improper assembly will cause the pump to malfunction, resulting in electric shock or water leaks.

The procedure for disassembly and reassembly is shown here to the extent necessary for impeller replacement. A specialized environment and facilities are necessary for work on the mechanical seal and the motor parts. Contact your nearest dealer or Wacker Neuson representative in the event such repairs are necessary.

3.4 Disassembly

See Graphic: wc_gr000411

Note: For assembly or disassembly, place the pump on its side.

Note: It is not necessary to drain the oil for disassembly and inspection of the impeller (**w**) or volute (**aa**). However, drain oil if further disassembly and testing is required.

3.4.1 Remove three nuts (**af**) and the suction strainer (**ac**).

3.4.2 Remove volute (**aa**) and volute gasket (**ah**).

3.4.3 While keeping the impeller (**w**) from rotating, remove stirrer nut (**z**), lockwasher (**y**) and washer (**x**).



Impeller vanes may be very sharp due to excessive wear. Handle with care.

3.4.4 Remove impeller (**w**).

Note: If the parts are worn or damaged, make sure to replace them with new ones.

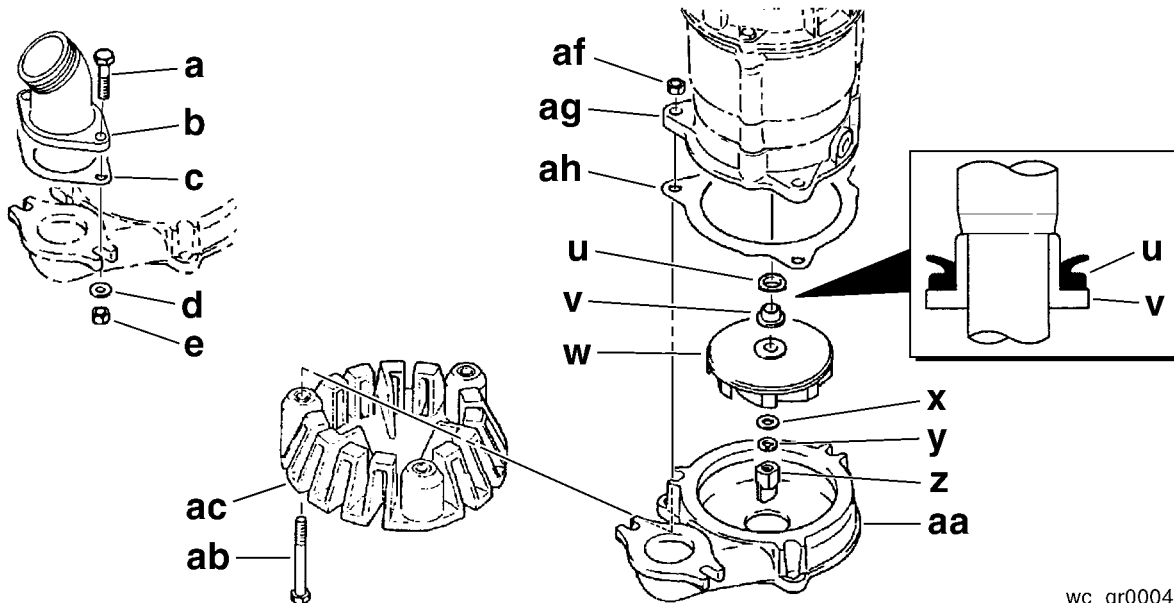

wc_gr000411

3.5 Impeller Inspection

See Graphic: *wc_gr000411*

- 3.5.1 Visually inspect impeller (**w**) for corrosion, wear or damage. Worn impellers compromise peak performance.
- 3.5.2 Visually inspect impeller key and rotor shaft keyway for signs of uneven wear.
- 3.5.3 Visually inspect volute (**aa**) casting for cracks, wear and damage. Look for signs of wear on volute cutwaters and surfaces facing impeller.

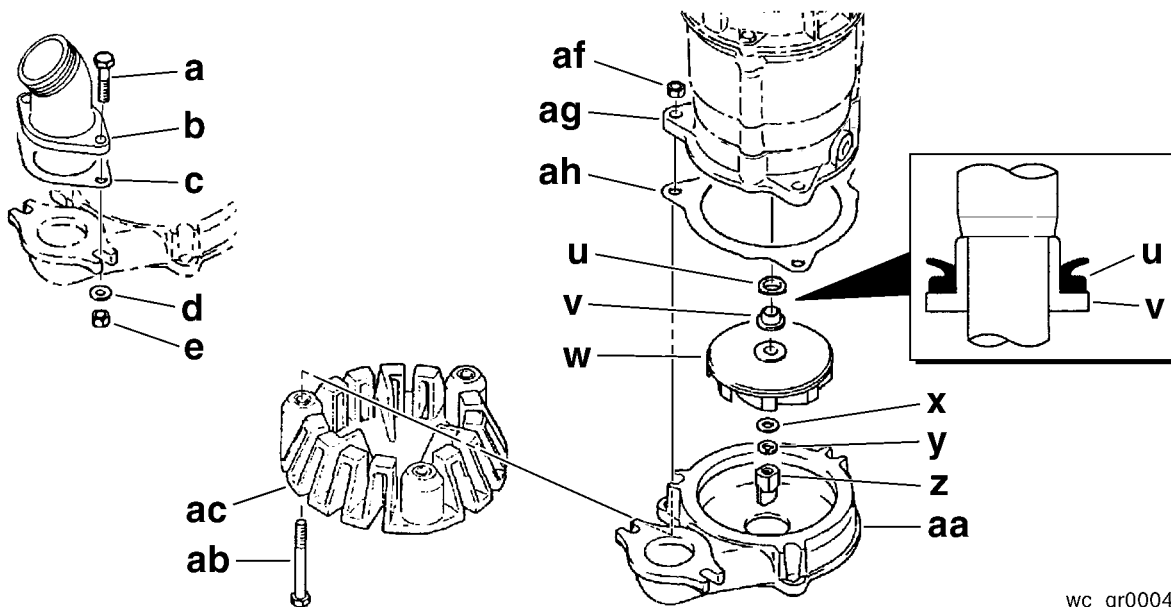

wc_gr000411

3.6 Impeller Reassembly

See Graphic: *wc_gr000411*

Note: *If, upon inspection and testing, a pump component requires replacement, use only original manufacturer's replacement parts.*

- 3.6.1 Turn pump on its side.
- 3.6.2 Pre-assemble the dust seal **(u)** and sleeve **(v)**. Slide the two pieces **(u & v)** onto the rotor shaft. DO NOT apply oil to the surface where the dust seal **(u)** contacts the sleeve **(v)**.
- 3.6.3 Align keyway of impeller **(w)** with keyway of rotor (not shown) and push impeller **(w)** onto rotor shaft.
- 3.6.4 Secure with washer **(x)**, lockwasher **(y)** and stirrer nut **(z)**.
- 3.6.5 While holding the impeller from rotating, tighten stirrer nut **(z)**.
- 3.6.6 Position volute **(aa)** on suction strainer **(ac)**, aligning with the three bolts **(ab)** protruding from the suction strainer **(ac)**.
- 3.6.7 Replace gasket **(ah)** on top of volute **(aa)**.
- 3.6.8 Lift and hold remaining pump assembly in an upright position, align three mounting flanges and lower into place.
- 3.6.9 Assemble and secure three nuts **(af)**.
- 3.6.10 Tighten three nuts **(af)**.
- 3.6.11 Pre-test pump to verify proper operation.
- 3.6.12 Performance test pump. Test results should be:

Maximum head	>	10.06m (33ft)
Maximum volume	>	170.3 ltr/min (45gpm)

3.7 Troubleshooting

Before ordering repairs, carefully read through this manual, then repeat the inspection. If the problem remains, contact your nearest dealer or Wacker Neuson representative.



Always turn off the power before inspecting the pump. Failure to observe this precaution can result in serious accident.

Problem / Symptom	Reason / Remedy
Pump will not start	<ul style="list-style-type: none"> • Power is off. Restore power. • Cable assembly is cut or not connected properly. Repair/replace the cable or fix the connection. • Impeller is clogged. Inspect the pump and remove any debris.
Pump stops soon after starting (Motor protector operates)	<ul style="list-style-type: none"> • Impeller is clogged. Remove debris. • Low voltage. Provide the rated voltage, or make sure the cable assembly extension is the proper standard. • Wrong power frequency. Check the nameplate, and replace the pump or the impeller. • Extended operation with a clogged strainer. Remove debris from the strainer.
Pump does not stop automatically	<ul style="list-style-type: none"> • Float (if equipped) is obstructed, not moving freely, or malfunctioning. Remove obstructions. Repair or replace float switch if necessary. • Water level of float (if equipped) set lower than pump's minimum operating water level. Set float higher than pump's minimum operating water level. • Malfunction in level relay unit. Repair or replace level relay unit. • Electrode shorted by debris. Use sandpaper to remove debris from electrode. • Electrical interference in vicinity of pump. Check for tangled wires around electrode. Check for nearby electrical devices that could generate electromagnetic interference; relocate pump if necessary.
Poor lift or discharge capacity	<ul style="list-style-type: none"> • Faulty motor. Repair or replace the motor. • Excessive sand is discharged. Place the pump on a block or other base to prevent the sand from being sucked into it. • Worn out impeller. Replace. • Sharply bent or clogged hose. Straighten out any sharp bends. Enclose the pump with a screen to keep away debris. • Strainer clogged or buried. Remove debris from the strainer, or place a block under the pump.
Heavy vibration or noise	<ul style="list-style-type: none"> • Damaged motor shaft. Contact dealer and replace motor.

4. Technical Data

4.1 Standard Specifications

Applicable Liquids, Consistency and Temperature	Rain Water, Ground Water, Sand-Carrying Water 0–40°C (32–104°F)	
Pump	Impeller	Semi-Vortex Type
	Shaft Seal	Double Mechanical Seal
	Bearing	Shielded Ball Bearing
Motor	Specification	Dry Submersible Induction Motor (2-Pole)
	Insulation	Class E
	Protection System	Miniature Protector
	Lubricant	SAE 10W/20W Such as: –Turbine Oil ISO VG #32 –Shell Victrolia Oil #27 –British Pet Energol THB #32 –Gulf Paramount #32 –Tellus #T22 Shell Oil –Shell Turbo T32
Connection	Coupling (NPT 2")	

4.2 Operating Specifications

Part No.		PST2 400 / PSTF2 400
Pump		
Electric Power	V/Ph/Hz	110/1/60
Rated Current	A	5.4
Starting Method		Capacitor-Run
Bore	mm (in.)	50 (2)
Output	kW (Hp)	0.40 (0.50)
Maximum Head	m (ft.)	12 (39)
Maximum Capacity	L/min (GPM)	200 (53)
Maximum Pressure	psi	16.8
Solid Size Capacity	mm (in.)	9.5 (0.4)
Weight*	Kg (lbs.)	11.3 (25)

*The weight (mass) given above is the operating weight of the pump itself, not including the cable assembly.

4.3 Dimensions

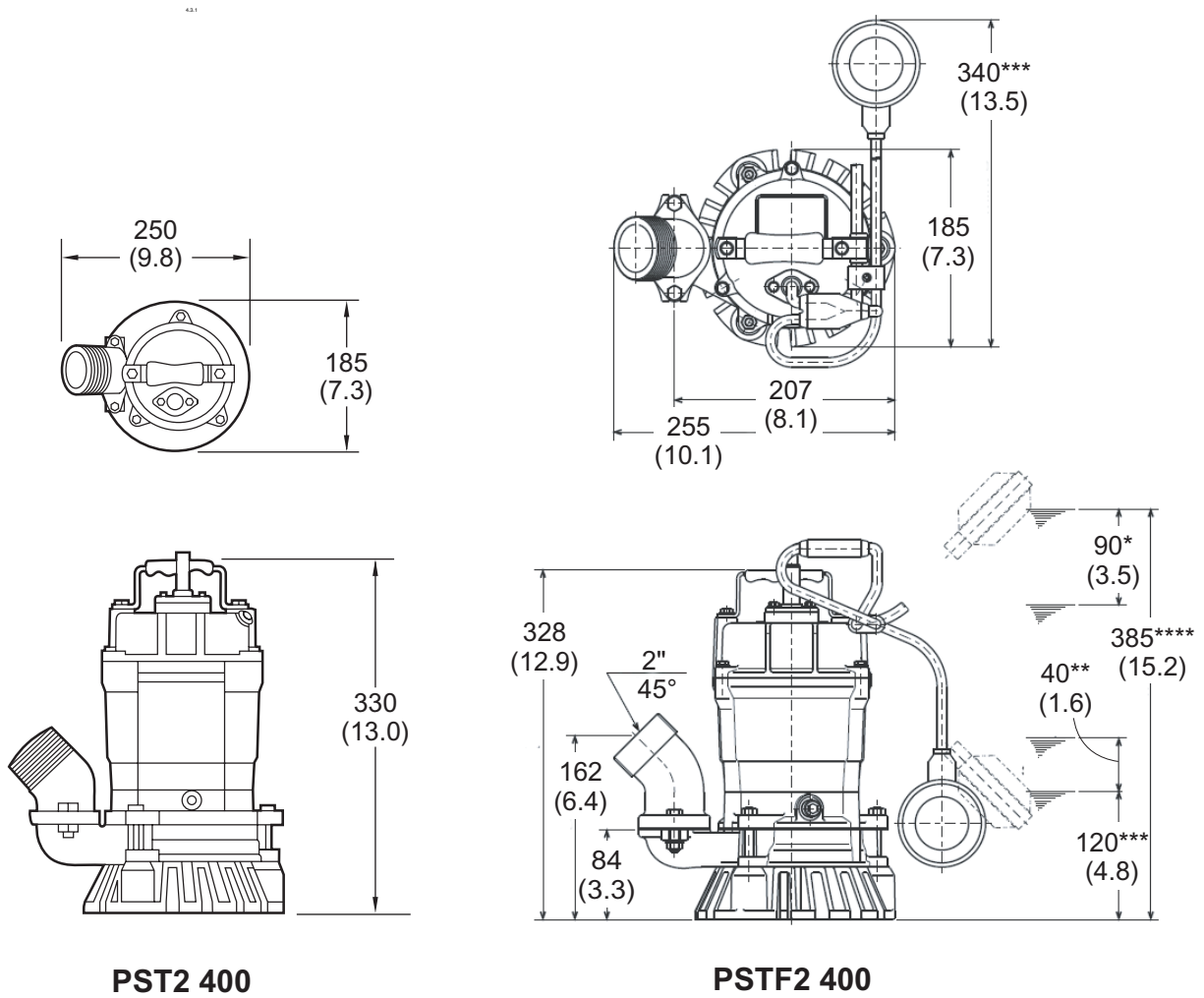

PST2 400

PSTF2 400

wc_gr006191

- *Start range
- ** Stop range
- *** Minimum
- **** Maximum

PORTABLE PUMPS

www.aem.org



SAFETY MANUAL

FOR OPERATING AND MAINTENANCE PERSONNEL

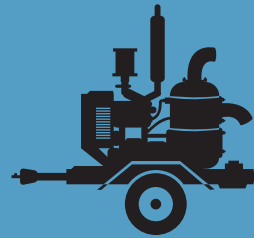
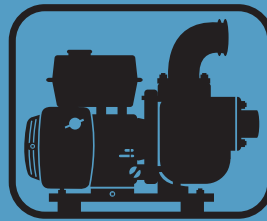

SAFETY ALERT SYMBOL



This Safety Alert Symbol means
ATTENTION is involved!

The Safety Alert Symbol identifies important safety messages on machines, safety signs, in manuals, or elsewhere. When you see this symbol, be alert to the possibility of personal injury or death. Follow the instructions in the safety message.

Why is SAFETY important to YOU?

3 BIG REASONS

- **Accidents KILL or DISABLE**
- **Accidents COST**
- **Accidents CAN BE AVOIDED**

NOTICE OF COPYRIGHT PROTECTION

AEM Safety Manuals are protected as a copyrighted work with ownership duly registered with the Copyright Office, Washington, D.C. Any reproduction, translation, decompiling or other use of an AEM Safety Manual, or portion thereof, or the

creation of derivative works based on an AEM Safety Manual, without the prior written approval of AEM is expressly prohibited. Copyright infringement can result in civil and criminal sanctions, damages and other penalties being imposed.

Copyright © 2004— Association of Equipment Manufacturers

1

REFERENCES

The following is a partial list of referenced material on safe operating practices:

U.S. Department of Labor publishes safety and health regulations and standards under the authority of the Occupational Safety and Health Act for the general construction and mining industries.

U.S. Department of Labor
Washington, DC 20210

NFPA — National Fire Protection Association
P.O. Box 9101
1 Battery March Park
Quincy, MA 02269-9101

SAE — Society of Automotive Engineers, Inc.
400 Commonwealth Drive
Warrendale, PA 15096
Publishes a list, "Operator Precautions" SAE J153
MAY 87.

AEM — Association of Equipment Manufacturers
111 East Wisconsin Avenue
Milwaukee, WI 53202

CONTENTS

	Page	Section
FOREWORD.....	4	
FOLLOW A SAFETY PROGRAM	5	1
PERFORM MAINTENANCE SAFELY	7	2
PREPARE FOR SAFE OPERATION	9	3
WORK SAFELY – Pumps In General	10	4
WORK SAFELY – Engine Driven Pumps.....	13	5
WORK SAFELY – Electric Motor Driven Pumps.....	15	6
WORK SAFELY – Submersibles	17	7
TEST YOUR KNOWLEDGE	19	8
FINAL WORD TO THE USER	20	9

FOREWORD

This safety manual is intended to point out some of the basic situations which may be encountered during the normal operation and maintenance of your equipment, and to suggest possible ways of dealing with these conditions.

Additional precautions may be necessary, depending on application, pump type, configuration and attachments used, conditions at the work-site or in the maintenance area. The manufacturer has no direct control over pump application, operation, inspection, lubrication or maintenance. Therefore, it is your responsibility to use good, safe, practices in these areas.

The information provided in this manual supplements the specific information about your pump that is contained in the manufacturer's manual(s). Other information which may affect the safe operation of your pump may be contained on safety signs, decals, markings, insurance requirements, employer's safety programs, safety codes, local, state/provincial and federal laws, rules and regulations, contracts, agreements and warranties.

It is your responsibility to read and understand this safety manual and the manufacturer's manual(s) before operating your pump. This safety manual takes you step-by-step through your working day. If you do not understand any of this information, or if errors or contradictions seem to exist, consult with your supervisor before operating your pump.

IMPORTANT: If you do not have the manufacturer's manual(s) for your particular pump, get a replacement manual from your employer, equipment dealer, or manufacturer of your pump. Keep this safety manual and the manufacturer's manual(s) with your pump.

Unauthorized modifications of pumps create hazards. Pumps must not be modified or altered unless prior approval is obtained from the manufacturer.

DO NOT PUMP VOLATILE/FLAMMABLE OR CAUSTIC/CORROSIVE LIQUIDS.

REFER TO THE OWNER'S MANUAL OR CONSULT WITH THE MANUFACTURER FOR THE PROPER PUMP MATERIALS IF YOU ARE TO PUMP HAZARDOUS CAUSTIC/CORROSIVE LIQUIDS.

FOLLOW A SAFETY PROGRAM

KNOW THE RULES

Every employer is concerned about safety. Safe operation and proper maintenance of your pump can prevent accidents. **KNOW** the rules — **LIVE** by them. (FIG. 1)

When starting work at a new site, check with the designated safety coordinator for specific safety instructions. **DON'T LEARN SAFETY THE HARD WAY.**

Know the meaning of all hand signals, signal flags, signs and markings.

Know the traffic rules used at the work site. Know who the signal man is; watch and obey his signals.

Know where the fire extinguishers and first aid kits are kept and how to use them. Know where to get proper aid and assistance when needed.

Use common sense to avoid accidents. If an accident does occur, be prepared to react to it quickly and effectively.

NEVER PANIC.

Remember that **YOU are the key to safety.** Good safety practices not only protect you but also protect the people around you. Study this manual and the manufacturer's manual(s) for your specific pump. Make them a working part of your safety program. Keep in mind that this safety manual is written for only this type of equipment. Practice all other usual and customary safe working precautions, and above all (FIG. 1).

REMEMBER — SAFETY IS UP TO YOU

**YOU CAN PREVENT
SERIOUS INJURY OR DEATH**



FIG. 1

1

5

FOLLOW A SAFETY PROGRAM

KNOW WHAT IT IS?

Consult your supervisor for specific instructions and personal safety equipment required.

For instance, you may need:

- Hard Hat
- Safety Shoes
- Eye Protection
- Respirators
- Heavy Gloves
- Reflector Vests
- Hearing Protection
- Face Protection
- Back Supports
- Other job related specific items

Do not wear loose clothing or any accessory — flopping cuffs, untied shoe-laces, dangling neckties and scarves, rings, wrist watches, or other jewelry — that can catch on protruding or moving parts or controls. Long hair should be securely bound to prevent entanglement with moving parts. (FIG. 3)



FIG. 2



FIG. 3

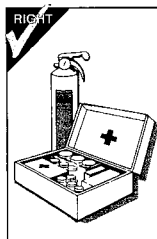

FIG. 4

BE ALERT!

Know where to get assistance. Know how to use a first aid kit and fire extinguisher or fire suppression system. (FIG. 4)

BE AWARE!

Take advantage of training programs offered.

Safety programs should require that one person at each jobsite be assigned the overall responsibility and authority for safety. Know who the person is, and **COMMUNICATE** with them.

Know what the jobsite rules are, and **FOLLOW THE RULES.** Be safety conscious, responsible and reliable. Think about safety **BEFORE** something happens.

BE CAREFUL!

Human error is caused by many factors: carelessness, fatigue, overload, preoccupation, incompatibility between operator and the equipment, drugs, and alcohol to name a few. Damage to the equipment can be fixed in a short period of time, but injury, or death has a lasting effect.

For your safety and safety of others, encourage your fellow workers to act within safety rules.

1

6

PERFORM MAINTENANCE SAFELY

CLOTHING AND PERSONAL PROTECTIVE ITEMS

ALWAYS wear appropriate safety glasses, goggles or face shield when working. (FIG. 2) Proper eye protection can keep flying particles from grinding, drilling or hammering operations, or fluids such as fuel, solvents, lubricants and brake fluids from damaging your eyes. Normal glasses do NOT provide adequate protection.

ALWAYS wear a hard hat and safety shoes. (FIG. 2) ALWAYS wear hearing protectors when exposed to high noise levels for extended periods. ALWAYS wear a respirator when painting or exposed to dusty conditions. ALWAYS keep your pockets free of loose objects which can fall out and drop into machinery. (FIG. 5) Heavy gloves should be worn for many operations.

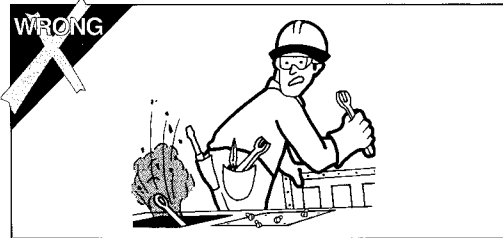

FIG. 5

EXHAUST FUMES

Engine exhaust fumes can cause sickness or death. If it is necessary to run an engine in an enclosed area, remove the exhaust fumes from the area with an exhaust pipe extension. If you do not have an exhaust pipe extension, be positive the area is adequately ventilated. (FIG. 6)



FIG. 6

HEAVY PARTS

Handle tools and heavy parts sensibly — with regard for yourself and other persons. Lower items — don't throw or drop them.

ALWAYS use proper hoisting equipment for lifting heavy loads.

ALWAYS use a back brace when lifting by hand.

2

7

PERFORM MAINTENANCE SAFELY

FIRE PREVENTION

Whenever possible use a nonflammable solvent to clean parts. Do not use gasoline or other fluids that give off harmful vapors.

If flammable fluids, such as gasoline or diesel fuel, must be used, extinguish open flames or sparks and DO NOT smoke.

Store dangerous fluids in a suitable place, in approved containers which are clearly marked. NEVER smoke in areas where flammable fluids are used or stored. (FIG. 7)

Use proper nonflammable cleaning solvents. Follow solvent manufacturer's instructions for use.

Always remove all flammable material in the vicinity of welding and/or burning operations.

ALWAYS keep the floor in the work area clean and dry. Oily, greasy floors can easily lead to falls. Wet spots, especially near electrical equipment, can be hazardous. (FIG. 7)

Know where fire extinguishers are kept — how they operate — and for what type of fire they are intended.

Check readiness of any fire detectors and fire suppression systems.



FIG. 7

2

PREPARE FOR SAFE OPERATION

LEARN TO BE SAFE

NEVER operate a pump which is new to you without first being instructed in its proper operation. READ the operator's manual. If one has not been provided, GET ONE AND STUDY IT BEFORE OPERATING THE PUMP.

Know the meaning of all identification symbols on your controls and gauges. (FIG. 8)

Know the location of the emergency shut-down control if the machine is so equipped.

Before attempting to operate the pump, know the capabilities and limitations of the pump. Familiarize yourself with controls and instruments — their locations and functions.

Keep hands, levers and knobs clean of oil or grease to prevent slipping.

Carefully read and follow the instructions on all safety signs and decals on the pump. Keep safety signs in good condition. Replace missing or damaged safety signs.



FIG. 8

CHECK IT OUT!

Know what safety devices your machine is equipped with ... and see that each item is securely in place and in operating condition. (FIG. 9)

For example:

- Drawbar Coupling Chains and Pins
- Alarms and Warning Lamps
- Reflectors
- Guards and Shields
- Drain Covers, Plugs, and Caps
- Shut-Down Devices
- Leveling Jacks
- Pressure Relief Devices
- Lifting Devices

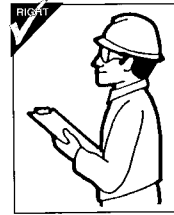

FIG. 9

NEVER START OR OPERATE A PUMP KNOWN OR SUSPECTED TO BE DEFECTIVE OR MALFUNCTIONING.

If your daily check uncovers any items that need attention — repair, replacement, or adjustment — report them promptly. The most minor malfunction could be the result of more serious trouble — or can cause it, if pump is operated. When in doubt, attach an OSHA Lockout/Tagout device tag to the control panel to disconnected electrical power supply at breaker, on electrically driven pumps and disconnect the battery and/or spark plug wire on engine driven pumps.

3

9

WORK SAFELY — Pumps In General

SAFE WORKING PROCEDURES

USE COMMON SENSE! Most accidents can be avoided by using common sense and concentrating on the job to be done.

ONLY EXPERIENCED AND QUALIFIED personnel should install and operate pump equipment.

KNOW THE PROPER starting procedure for your equipment. Follow the manufacturer's operation manual ... to the letter.

DO NOT operate a pump without all guards and shields in place. (If OSHA required guards are damaged or misplaced, contact the manufacturer for a replacement.)

When **lifting pump** use only lifting equipment in good repair and with adequate capacity. Follow manufacturer's lifting recommendation.

Check all lubricant levels before pump installation in accordance with manufacturer's maintenance programs.

Keep hands and feet clear of moving parts. DO NOT stick fingers into a pump when in operation. Check suction strainer and hose regularly for proper submergence and to be sure it is free of obstructions.

NEVER operate a self-priming pump unless the volute is filled with liquid. The pump will not prime when dry.

PUMP only liquids for which the pump has been designed to handle.

DO NOT pump flammable, corrosive or caustic materials unless the pump and piping are explicitly designed for that purpose.

NOTE the direction of rotation — operation of a pump in the wrong direction can cause the impeller to unscrew and damage the volute case.

A pump should not be operated against a closed valve or other no flow conditions. Refer to the pump manufacturer's recommended practice for start-up, operation and shut-down procedures. **DO NOT** close down or restrict a discharge hose. **Be careful** of discharge hose whipping under pressure.

4

WORK SAFELY – Pumps In General

MAKE CERTAIN that whatever is to be connected to the pump is not subjected to pressures greater than those given in the manufacturer's instructions.

MAKE CERTAIN all connections are securely made and hoses under pressure are secured, with appropriate safety devices, to prevent whipping.

BE AWARE OF LIGHTNING. Stay clear of the pumping equipment during electrical storms. It can attract lightning. (FIG. 10)

OVERHEATING PRECAUTIONS

Overheated pumps can cause severe damage to the equipment and can cause severe physical burns and injury.

Operating a pump with the suction and/or discharge valve closed is a principal cause of overheating. Approach cautiously any pump that has been in operation.

DO NOT remove hoses from a pump until the system is properly cooled to ambient temperature.

DO NOT remove the cover plate or drain plugs from any overheated pump. Allow the pump to cool. Check pump temperature before opening fill port or drain plug.

If overheating of the pump casing occurs:

- **STOP** the pump immediately.
- Allow the equipment to **cool completely**.
- Slowly and cautiously **vent the pump**.
- **Refer to the manufacturer's instruction manual** before restarting the unit.
- Remove hoses carefully. Heated water can be in hoses and static head produces pressure.

4

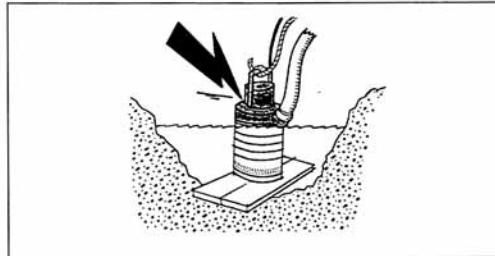

FIG. 10

11

WORK SAFELY – Pumps In General

BEFORE STARTING

Check the pump thoroughly at delivery for any shipping damage.

Locate the pump in an accessible location, as close to the liquid as possible.

Secure the pump after it is placed in its intended operating position so it does not tip, roll, slide or fall.

IMMEDIATELY ON STARTING THE PUMP

Observe gauges, instruments and warning lights to ensure that they are functioning and their readings are within the normal operating range.

- Be sure the immediate work area is safe for operation.
- Operate controls; make certain all operate properly and "feel" right. Accustom yourself to the "feel" of the equipment.
- Listen for any unusual noises, smell for any unusual odors; look for any signs of trouble.
- Be sure to open all manual valves slowly to prevent **WATER HAMMER**.
- Check all warning and safety devices and indicators.

• If safety-related defects or malfunctions are detected, **SHUT DOWN** the equipment. Correct the problem, or notify your supervisor. **DO NOT OPERATE EQUIPMENT WITH DEFECTS OR MALFUNCTIONS UNTIL CORRECTED.**

• **If an unsafe condition cannot be remedied immediately, notify your supervisor and tagout/lockout** the pump on the start switch and/or appropriate, prominent location. (FIG. 11)

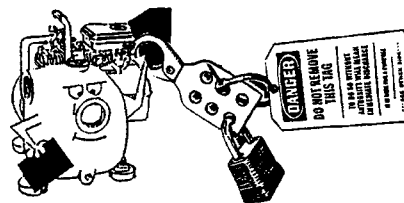

FIG. 11

4

WORK SAFELY – Engine Driven Pumps

SAFE WORKING PROCEDURES

Do not jump start engine battery.

When operating internal combustion engines in an enclosed area, always make provisions to pipe exhaust fumes to the outside.

EXHAUST FUMES CAN KILL: Do not operate engine driven pump equipment in a confined or enclosed space without adequate ventilation.

Exhaust gases are odorless and deadly poison.

DO NOT TOUCH: The exhaust system components get very hot and stay hot for some time after shutting the engine off.

Follow engine manufacturer's instructions explicitly on hand cranking.

Do not shut down high head pumps quickly:

- A) Throttle back slowly
- B) Open by-pass line
- C) Should have a check valve
- D) Slowly close gate valve on discharge if so equipped.

Check for fuel, oil and hydraulic fluid leaks, worn and damaged hoses/lines or power cables.

Refueling

When refueling, the following precautions must be followed:

- Add fuel of proper type and grade, only when the pump is not running and engine is cool.
- Fuel in well ventilated area.
- Turn off all electrical switches.
- Keep lighted smoking materials, flames or spark producing devices at a safe distance while refueling.
- Keep fuel nozzle in contact with tank being filled, or provide a ground to prevent static sparks from igniting fuel.
- **Do not spill fuel on hot surfaces.**
- Clean up spillage immediately.
- Do not start engine until fuel cap is secured to the fuel tank.
- **Always** make sure that fuel is being put in the fuel tank, motor oil in the proper location and hydraulic oil into hydraulic oil reservoirs.

5

13

WORK SAFELY – Engine Driven Pumps

Maintenance and Repair

All installations, operations and maintenance should be in accordance with pump and engine manufacturer's recommended operation and maintenance program. These manuals should be kept available with the equipment.

Maintenance work can be **hazardous** if not done in a careful manner. All personnel should realize the hazards and strictly follow safe practices.

NEVER perform any work on the equipment unless authorized to do so.

BEFORE ANY maintenance **work** is to be done, a LOCKOUT/TAGOUT standard device and procedure should be implemented. Prior to removal of LOCKOUT/TAGOUT, the equipment must be fully operational and all personnel accounted for. Except in cases of emergency, the removal of the LOCKOUT/TAGOUT should be done **ONLY** by the initiating person prior to the return to start-up (see page 12, Fig. 11).

BEFORE doing any major work, disconnect the ignition and battery if so equipped.

Always replace safety devices removed during service or repair before returning pump to operation.

Battery Servicing

- **Always wear** safety glasses and gloves when servicing or working with batteries.
- **Before servicing battery**, turn off electrical systems, then disconnect ground terminal clamp. Before installing a battery, turn off electrical equipment, then connect the battery ground clamp **last**.
- **Maintain** electrolyte at the recommended level. Check level frequently. Add distilled water to batteries only when starting up, never when shutting down.
- **Use a flashlight** to check level. **NEVER** use a flame.
- **Do not short** across battery terminals — the spark could ignite the battery gases.

Battery acids will **burn skin**, eat holes in clothing, and can **cause blindness** if splashed in eyes.

If you spill acid on yourself flush skin immediately with lots of water. Apply baking soda to help neutralize the acid. If acid gets into the eyes, flush immediately with large amounts of water and seek proper medical treatment immediately.

5

14

WORK SAFELY – Electric Motor Driven Pumps

SAFE WORKING PROCEDURES

Allow only qualified personnel to INSTALL, WIRE AND OPERATE electric motor driven pumps. Whenever electricity is present there is the possibility of **electrocution**.

NEVER use a pump/motor in an explosive atmosphere if it is not exclusively designed for the application.

Always ground electrical units.

Make certain to connect pump motor to the right phase and voltage.

Do not run pump if voltage is not within limits.

Make sure motor rotation is in accordance with impeller rotation (which should be indicated somewhere on the pump — check the manufacturer's manual).

Make all electrical installations in accordance with National Electric Code, State and Local electrical codes.

Never use gas piping as an electrical ground.

Make sure the related electrical circuits are dead and locked out before performing any maintenance.

Follow motor manufacturer's recommended maintenance and operation instructions.

If circuit breaker or fuse is tripped, examine the system for the problem before restarting pump.

NEVER use the power cord to aid lifting the pump.

NEVER operate a pump with a plug-in type power cord without a ground fault circuit interrupter.

NEVER use cords with frayed, cut or brittle insulation. Check the cord on the pump for nicks in the insulation and for sound connections to the ground fault interrupter plug and motor.

NEVER let extension cords or the plug connections lay in water. Locate the pump so that the cord cannot fall into any water or be submerged by rising water, unless the pump is designed for such use.

NEVER handle energized power cords with wet hands.

MOTOR OVERLOAD: do not exceed the manufacturer's recommendation for maximum lift or discharge head. See manufacturer's published curve for proper sizing of motors. A misapplied motor can overheat.

6

15

WORK SAFELY – Electric Motor Driven Pumps

Pump Maintenance and Repair

MAKE SURE the pump is disconnected from the power source or the appropriate circuits are dead and OSHA Lockout/Tagout is applied before doing any maintenance or repair work on the pump.

Maintenance work can be **hazardous** if not done in a careful manner. All personnel should realize the hazards and strictly follow safe practices.

NEVER perform any work on the equipment unless authorized to do so. (FIG. 11) Before performing any maintenance or repair work, consult the manufacturer's instruction manual for recommended procedures.

Pumps with float switches or other automatic devices can start without warning if not properly locked out.

BEFORE ANY maintenance work is to be done, a LOCKOUT/TAGOUT standard device and procedure should be implemented. Prior to removal of LOCKOUT/TAGOUT, the equipment must be fully operational and all personnel accounted for. Except in cases of emergency, the removal of the LOCKOUT/TAGOUT should be done **ONLY** by the initiating person prior to the return to start-up.

ALWAYS replace safety devices removed during the service or repair before returning pump to operation.

NEVER use the power cord to aid in lifting the pump.

Sizing Extension Cords

Use the following chart to select the correct size extension cord to prevent excessive amperage draw or voltage drop which would cause the motor to overheat. **Cables that are too long or coiled** can cause a voltage drop. **Be aware** that strong sunlight can cause a voltage drop.

Amperes	Wire Gauge and Cord Length (in feet)		
	50	100	150
6	16	16	14
8	16	14	12
10	16	14	12
12	14	14	12
14	14	12	10
16	12	12	10

6

WORK SAFELY – Submersibles

SAFE WORKING PROCEDURES

ALLOW only qualified personnel to INSTALL, WIRE and OPERATE submersible pumps.

Whenever electricity is present there is the possibility of **electrocution**.

NEVER use a pump/motor in an explosive atmosphere, if it is not exclusively designed for that application.

ALWAYS ground the pump.

Make certain to connect the pump to the right phase and voltage.

DO NOT run the pump if voltage is not within limits. **Make all electrical installations** in accordance with National Electric Code, State and Local electrical codes.

Mount electrical control box in a vertical position, protected from the elements.

NEVER attempt to use the power cord or hydraulic hoses as a lifting or lowering device for submersibles. Attach a lifting cable to the manufacturer's recommended attachment point on the pump for lowering and lifting the pump. (FIG. 12)

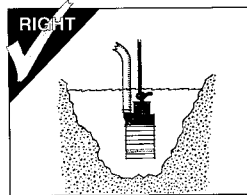

FIG. 12

NEVER position the pump directly on a soft, loose bottom. To attain maximum capacity and prevent excessive wear, position the pump so it will not burrow itself into sand or clay. Stand the pump on a plank, a bed of coarse gravel, within a perforated container, on a suitable floatation device, or retain it hanging freely by a lifting cable. (FIG. 13)

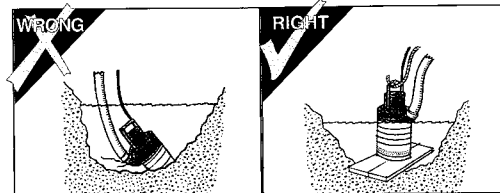

FIG. 13

7

17

WORK SAFELY – Submersibles

Pump Maintenance and Repair

MAKE SURE the pump is disconnected from the power source or the appropriate circuits are dead and OSHA Lockout/Tagout is applied before doing any maintenance or repair work on the unit.

Maintenance work can be **hazardous** if not done in a careful manner. All personnel should realize the hazards and strictly follow safe practices.

NEVER perform any work on the equipment unless authorized to do so. Before performing any maintenance or repair work, consult the manufacturer's instruction manual for recommended procedures.

BEFORE ANY maintenance work is to be done, a LOCKOUT/TAGOUT standard device and procedure should be implemented. Prior to removal of LOCKOUT/TAGOUT, the equipment must be fully operational and all personnel accounted for. Except in cases of emergency, the removal of the LOCKOUT/TAGOUT should be done **ONLY** by the initiating person prior to the return to start-up.

Check oil level ONLY when pump is cool.

USE ONLY recommended oil per manufacturer's recommendation.

INSPECT ELECTRICAL WIRING for worn or damaged insulation. **INSTALL** new wiring if wires are damaged. **After repairs are made, clean the equipment before putting the pump back into position.**



7

TEST YOUR KNOWLEDGE

Do you understand this AEM SAFETY MANUAL AND ITEMS SUCH AS ...

- Your safety program?
 - Your pump manufacturer's manual(s)?
 - Proper clothing and personal safety equipment?
 - Your pump's controls, warning signs and devices, and safety equipment?
 - How to properly inspect, mount, and start your pump?
 - How to check your pump for proper operation?
 - Your work area and any special hazards that may exist?
- Proper operating procedures?
 - Proper shutdown procedures?
 - Proper maintenance procedures?
 - Proper loading and unloading procedures for transporting?
 - Under what conditions you should not operate your pump?

If you do not understand any of these items, consult with your supervisor BEFORE operating your equipment!

8

19

FINAL WORD TO THE USER

Remember that **YOU are the key to safety**. Good safety practices not only protect you but protect the people around you.

You have read this safety manual and the manufacturer's manual(s) for your specific pump. Make them a working part of your safety program. Keep in mind that this safety manual is written for only this type of equipment.

Practice all other usual and customary safe working precautions, and above all —

**REMEMBER
SAFETY IS UP TO YOU
YOU CAN PREVENT SERIOUS
INJURY OR DEATH**

9

20

This manual is another in a series on the safe operation of machinery published by AEM.
For additional publications visit our web site at www.aem.org.



Association of Equipment Manufacturers

Toll free 1-866-AEM-0442

e-mail aem@aem.org

www.aem.org

